

BRAUN

ThermoScan
Instant Thermometer

IRT 1020
Type 6005
Home Model

English
Use Instructions
Guarantee
Service Centres

Important safeguards

The Braun ThermoScan Instant Thermometer is a sophisticated electronic instrument that has been carefully engineered for both accuracy and safety. The shape of the thermometer prevents it from being inserted far enough into the ear canal to damage the eardrum. However, basic safety precautions should always be observed, especially when using the thermometer on or near children.

Please read all instructions carefully before using this product

To use this instrument safely:

- This product is designed to measure human body temperature by detecting heat from the eardrum and surrounding tissue. Do not use the instrument for any other purpose. Do not use any other type of thermometer in the ear.
- Close supervision is necessary when using this thermometer on, near or by children or disabled persons.
- Keep lens filters out of reach of children.

To ensure long life and accurate operation of this precision instrument:

- This thermometer must only be used with genuine Braun ThermoScan Lens Filters. (LF 40).
- Do not use this thermometer without a new lens filter attached. After each use, discard it and replace with a new one. (See Care and Cleaning, page 17).
- If the thermometer is ever accidentally used without a lens filter attached, clean the lens. (See Care and Cleaning, page 17).
- Never submerge the Braun ThermoScan Instant Thermometer in water or any other liquid.

- When not in use, place the storage cover over the thermometer with a lens filter attached to protect it from damage and dirt.
- Store unit and lens filters in a dry location free from dust and contamination where the temperature remains fairly constant and within the range of 16°C to 40°C (61°F to 104°F).
- Store lens filters away from direct sunlight and fluorescent lighting.
- Do not drop, mishandle, or expose to temperature or humidity extremes [outside the range of -20°C to 50°C (-4°F to 122°F), 15-95 % RH non-condensing.] Do not use if the thermometer malfunctions or has been damaged in any manner.
- There are no user-serviceable or replaceable parts except the 9 volt battery and lens filters. Refer to page 74 for service information.
- **This product is intended for household use only. Use of this thermometer is not intended as a substitute for consultation with your physician.**

For best results, use a 9 volt alkaline battery.

- Do not dispose of empty batteries in household waste. Take them to special local collection sites.



Thank you for purchasing the Braun ThermoScan Instant Thermometer

Unlike other thermometers that must be held in place for several minutes, the Braun ThermoScan Instant Thermometer takes a temperature in just one second. It takes a "picture" of the infrared heat given off by the ear drum and surrounding tissue, calculates, and displays an ear temperature on the digital readout.

But why take a temperature at the ear? Because the eardrum is close to and shares blood vessels with the hypothalamus, the temperature control centre of the brain. Therefore, temperatures taken from the ear reflect the body's "core", or internal temperature. (T_{is} is the temperature of the heart, brain and internal blood supply.) The ear is also a protected cavity, so, unlike oral temperatures, the accuracy of ear temperatures is unaffected by eating, drinking, smoking and breathing through the mouth. The ear is a dry cavity so cross-contamination through mucous membrane contact, a problem with oral and rectal sites, cannot occur. Also, the risk of bowel perforation, a concern when taking rectal temperatures on infants or children, is eliminated.

The Braun ThermoScan Instant Thermometer has been clinically proven to be safe and accurate. To ensure the best results, please take the time to read this manual completely and keep it handy for future reference.

IRT 1020 product specifications

Product type:	6005	
Technical Characteristics:		
Patient temperature range	34 - 42.2°C (93,2-108°F)	
Surrounding room temperature for operational range	116 - 40°C (61-104°F)	
Display resolution	0.1°C or °F	
Temperature scales (user selectable)	°C or °F	
Operating relative humidity (max)	80 %	
Long term storage ranges		
Temperature	-20 to 50 °C (-4 to 122°F)	
Humidity (max)	95 % noncondensing	
Display Mode:	Ear (☞)	
Power source:	One 9 volt alkaline battery (6 LR 61, MN 1604 9 V, alkaline)	
Weight (without batteries):	188 g (6.6 oz)	
Accuracy characteristics:*		
Applicable patient ages	All ages	
Laboratory error (max)		
Patient temperature range	Error °C	Error °F
37.0°C to 39.0°C (8.0°F to 102.0°F)	±0.1	±0.2
35.8°C to <37.0°C (96.4°F to <98.0°F)	±0.2	±0.3
>39.0°C to 41.0°C (>102.0°F to 106.0°F)		
<35.8°C or >41.0°C (<96.4°F or >106.0°F)	±0.3	±0.5

* Meets American Society for Testing and Materials (ASTM) Accuracy Standards E1112-86 over normal operating range.

Components and features

- Product includes the following components:
- Braun ThermoScan Instant Thermometer
 - Lens Filters (20, plus one on thermometer)
 - Storage Cover (See Figure 5)
 - Use Instructions
 - Labels

Not included, but required:

- One 9 volt alkaline battery (6 LR 61, MN 1604 9V, alkaline).

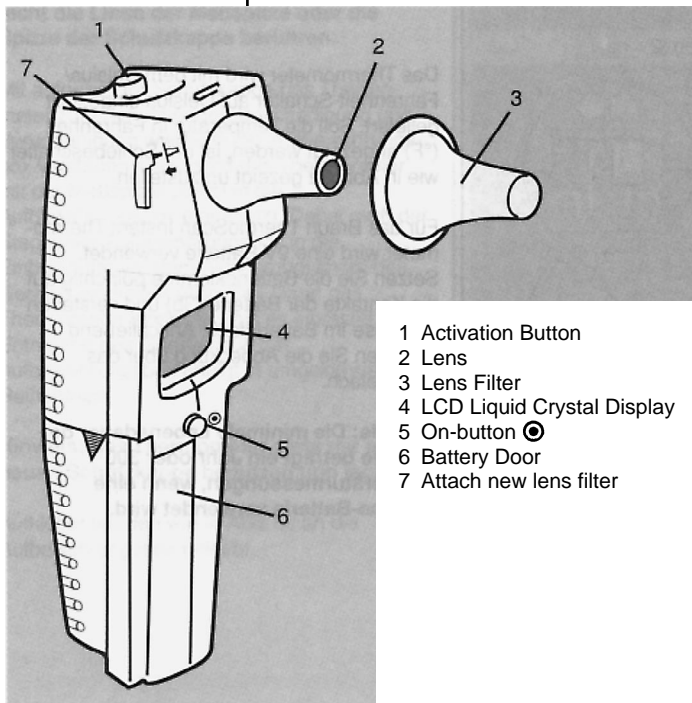

- 1 Activation Button
- 2 Lens
- 3 Lens Filter
- 4 LCD Liquid Crystal Display
- 5 On-button
- 6 Battery Door
- 7 Attach new lens filter

Figure 1

To remove the thermometer from the storage cover, slide it forward in the cover (Figure 2a, arrow 1), then lift up (Figure 2a, arrow 2).

Open the battery door by pressing in at the arrow and sliding the door down toward the base of the instrument (Figure 2b)

Preparing the Braun ThermoScan Instant Thermometer for use

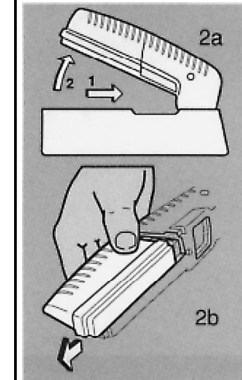

Figure 2

The thermometer is shipped with the Celsius/Fahrenheit switch set to Celsius. If you wish to have temperatures displayed in Fahrenheit (°F), slide the switch as shown (Figure 3a).

The Braun ThermoScan Instant Thermometer uses a 9 volt battery. To install it, snap the positive and negative terminals of the battery onto the appropriate receptacles on the connector (Figure 3b). Place the battery inside the compartment and slide the battery door back into place.

Note: Minimum battery life is one year or 300 temperatures when an alkaline battery is used.

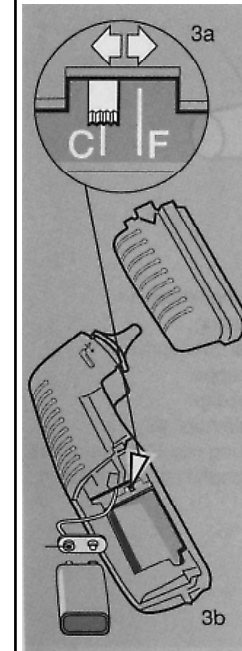

Figure 3

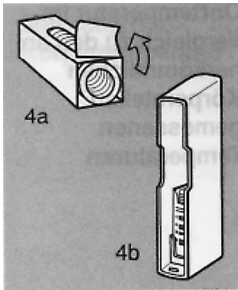

Figure 4

Lens filters are located inside the thermometer storage cover. Remove the box from the cover and open the box of lens filters by completely removing top of box (Figure 4a). You may return the box to the cover for convenient storage (Figure 4b).

The thermometer is shipped with a lens filter in place. To install a new lens filter, remove the one in place, then take a new one from the box and holding it by its edges, slide it onto the lens until it is snug and snaps in place.

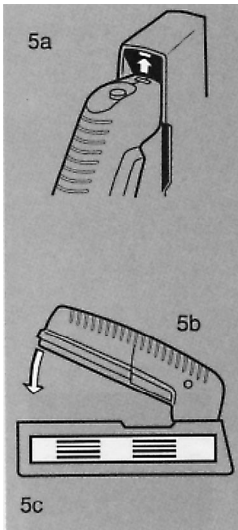

Figure 5

Caution: Do not touch the tip of the lens or lens filter when installing.

With a new lens filter in place, attach the storage cover to the thermometer to protect the lens from damage and dirt. Place the lens end of the thermometer into the storage cover first matching the indent in front of the activation button with the corresponding tab inside the cover (Figure 5a), then snap the opposite ends together (Figure 5b). To remove the unit from the storage cover, reverse this procedure.

Note: Always use and store the thermometer with a new lens filter attached.

Apply label to storage cover as indicated (Figure 5c).

The Braun ThermoScan Instant Thermometer displays ear temperature readings, which frequently cannot be compared directly to temperatures taken at the same time at another site. This is because the temperature measured at the ear with the Braun ThermoScan Thermometer more closely reflects any rapid changes occurring with the internal (core) body temperature.

Temperatures taken in the ear canal tend to reflect changes in internal body temperature sooner than oral, rectal or axillary (armpit) because the eardrum shares blood supply with the temperature control center in the brain. Oral temperatures are influenced by eating, drinking, smoking, rapid breathing, thermometer placement or the inability of the person to close their mouth completely. Axillary temperatures have not been found to be accurate indicators of core temperatures except in newborns.

Temperature changes are also seen sooner when measured in the ear canal. Studies show that rectal temperatures "lag" behind internal (core) body temperatures, especially during periods of rapid warming and cooling, as when you have a fever. This is due to the poor blood supply in this area, insulating effects of stool, and the presence of heat producing microorganisms located there.

How ear temperatures compare to temperatures taken at more traditional sites

Body temperature measurement

Normal body temperature is a “range”, not a single point, as temperature varies from person to person. A person’s temperature can rise with excessive clothing, hot weather or accelerated activity (such as crying or exercise). In order to observe these naturally occurring variations and determine the normal temperature range for each member of your family, practice taking temperatures on yourself and healthy family members at different times of the day to determine their “baseline” temperature. The normal range for ear temperatures taken with the Braun ThermoScan Instant Thermometer is from 35.8°C (96.4°F) to 38.0°C (100.4°F) for all ages.

Normal body temperature also varies with age. We have the highest temperatures when we are younger. About our eleventh year, body temperature begins to decrease gradually. The elderly population has the lowest body temperatures. For your reference, the following chart shows normal ear temperature ranges by ages groups for the Braun ThermoScan Instant Thermometer:



Normal Ear Temperature Range by Age

Years of Age	Celsius	Fahrenheit
0 - 2	36.4°C - 38.0°C	97.5°F - 100.4°F
3 - 10	36.1°C - 37.8°C	97.0°F - 100.0°F
11 - 65	35.9°C - 37.6°C	96.6°F - 99.7°F
>65	35.8°C - 37.5°C	96.4°F - 99.5°F

When consulting your physician about fever, remember to communicate that this is an ear temperature, referring to the appropriate ear temperature range in the chart above. Also, note the individual’s “baseline” temperature as an additional reference point.

1. Remove the thermometer from its storage cover. If stored properly, a new lens filter will already be in place. (See procedure on page 7.) **Do not use thermometer without lens filter attached.**

2. Depress the on-button  that is located directly below the LCD (liquid crystal display) to turn the power on. (See Figure 1)

- All segments on the LCD-display (Figure 6) will be shown for two seconds to indicate a fully functional display.
- The display will indicate  (not ready) while the unit is completing self test, then, within two seconds  (ready) indicating that the thermometer is ready to take a temperature (Figure 7). If no temperature is taken within two minutes, the thermometer will automatically shut off.

3. Stabilise the head. In infants, this is best achieved by laying them flat with the head rotated so the ear is up.

4. Perform an ear tug and position the thermometer. In order to take an accurate temperature, the thermometer must be positioned correctly in the ear. In addition, an “ear canal straightening” technique must be used to straighten the natural bend of the canal and ensure that the thermometer has a clear view of the eardrum.

- If you are right handed, hold the thermometer in the right hand and take the temperature in the right ear. If you are left handed, hold it in the left hand and use the left ear. This will help ensure proper placement.
- Perform an “ear tug” by using your free hand to grasp the outer edge of the top half of the ear and follow the steps in the chart below. To take your own temperature, an ear tug is best achieved by wrapping your free hand around the back of your head and grasping your ear from behind.

Continue pulling the ear until you are finished taking the temperature.

How to use the Braun ThermoScan Instant Thermometer

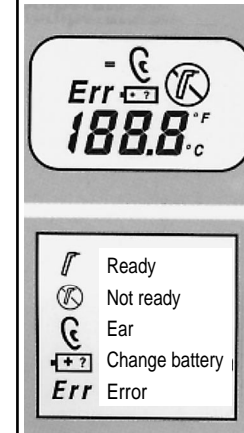

Figure 6

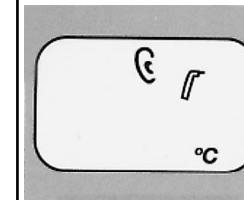

Figure 7

Ear tug and positioning technique

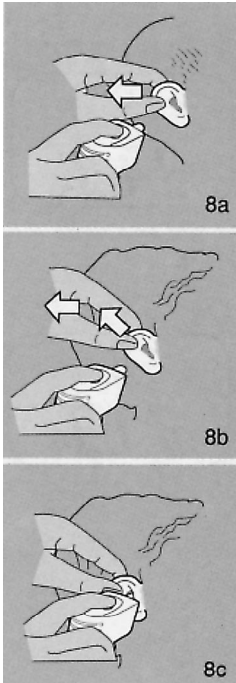

Figure 8

Children under 1 year

- **Ear Tug** Gently but firmly pull ear straight back (Figure 8a).
- **Positioning** Approach the ear from behind the child. Place the lens at the opening of the ear canal. Using a slight back and forth rocking motion, gently insert the thermometer, pointing the lens toward the opposite eye. Gently insert the lens as far as possible until the ear canal is fully sealed off (Figure 8c).

Children 1 Year to Adult

- **Ear Tug** Gently but firmly pull ear up and back (Figure 8b).
- **Positioning** Approach the ear from behind the person. Place the lens at the opening of the ear canal. Using a slight back and forth rocking motion, gently insert the thermometer, pointing the lens slightly in front of the opposite eye. Insert the thermometer as far as possible until the ear canal is fully sealed off (Figure 8c).

5. After the thermometer is correctly positioned, press the "Activation" button with the index finger and hold fully depressed for one second.

NOTE: In the following situations, it is recommended that you take three temperatures in the same ear. If they differ, use the highest reading.

- (1) Infants in the first 90 days of life.
- (2) Children under three years of age who have a condition such as a compromised immune system and for whom the presence or absence of fever is critical.
- (3) When you are first learning to use the ear thermometer until you are comfortable with the technique and are obtaining consistent readings.

No more than three readings should be taken consecutively in the same ear since repeatedly inserting the thermometer into the ear canal can lower the reading.

6. When the unit is removed from the ear, the temperature will be shown on the display (Figure 9) until another temperature is taken or the unit powers down. The thermometer is ready to take a new temperature when  (ready) appears on the screen along with the last temperature reading (Figure 10). To help ensure accuracy, you must change the lens filter after each reading. Inspect the lens whenever you replace a lens filter. Two minutes after the final temperature reading, the thermometer will automatically turn itself off to conserve battery power.
7. Before storing the thermometer in its storage cover, change the lens filter (see page 17 "Care and Cleaning") and check to make sure the filter is intact with no visible scratches or holes. If a lens filter is damaged, dispose of it and replace it with a new one. Additional lens filters (LF 40) are available at most stores carrying Braun ThermoScan Instant Thermometers, or contact Braun for a store near you.



Figure 9

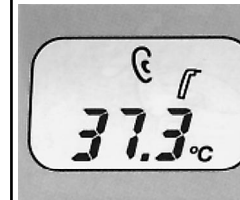



Figure 10





Temperature taking hints

- It is important to use an ear tug, point the thermometer lens toward the eardrum and gently insert far enough into the ear canal to obtain an accurate reading.
- When taking a temperature on another person, it may be more difficult to consistently position the thermometer in their ear. If the person whose temperature is to be taken is old enough, ask for assistance in the positioning process.
- It is not uncommon for a person's temperature in the right ear to be slightly different than in the left ear. When monitoring temperature during illness, use the same ear to maintain a constant frame of reference.
- If a person has been sleeping on one ear for an extended period of time, the temperature of that ear may measure higher than normal. Wait a few minutes before taking a temperature to allow the ear to stabilise.
- The best temperature measurements are taken when the ear is free of obstruction. If you suspect an obstruction or excessive earwax build up, contact your physician.
- The normal range for ear temperatures taken with a Braun ThermoScan Instant Thermometer is 35.8°C to 38°C (96.4°F to 100.4°F).
- To protect the instrument lens, always keep a lens filter attached. If the thermometer is accidentally used without a filter, gently clean the lens and surrounding area (see instructions on page 17). It is also a good idea to inspect the lens whenever you replace a lens filter.
- **The thermometer is designed to take accurate temperatures with a lens filter in place. Temperatures taken without a lens filter attached will not be accurate and can damage the lens. Change the lens filter after each use.**

Troubleshooting

The Braun ThermoScan Instant Thermometer has been designed to provide feedback to ensure proper usage and accurate temperature taking. In many cases this means that instead of displaying a temperature that is not meaningful, a message will be displayed that will help you take corrective action. These messages are outlined below:

LCD-Display	Situation	Solution
Err 1	Appears after on-button  is pushed if the temperature of the Braun ThermoScan is not within its operating range. 16°C to 40°C (61°F to 104°F).	Move the thermometer to a room within the 16°C to 40°C (61°F to 104°F) operating range for 30 minutes and retake temperature.
Err 2	appears after pushing the activation button if temperature measurement is not within typical human temperature range of 34°C-42,2°C (93,2°F to 108°F).	Be sure a lens filter is attached and the thermometer is properly inserted, fully sealing off the ear canal. Take the temperature again.
Err 3	Appears after the activation button is pushed if it is not held down for a full second.	Take the temperature again by slowly depressing the activation button and holding it down for one full second.
Err 4	Appears after activation button is pushed if the internal temperature of the thermometer is changing to rapidly.	Allow the thermometer to remain for 30 minutes in the room where the temperature is being taken.
Err 000	The Braun ThermoScan performs a self diagnostic test on its circuitry after each initial activation and when a new battery is installed. If any faults are detected, „Err 000“ will be displayed.	Wait 2 minutes until the thermometer switches itself off automatically (blanc LCD-display). Push on-button  and take temperature again. If „Err 000“ is repeated, contact Braun.

LCD-Display	Situation	Solution
	The activation button was pushed sooner than 8 seconds after the previous activation. The countdown in seconds will also appear until another temperature can be taken.	Wait until the display shows  (ready) before taking another temperature.
 Flashing	The battery power is getting low. There is enough remaining power for about 10 days or 10 temperatures.	Install a fresh battery.
 Constant	The battery is so low that no more temperatures can be taken.	Install a fresh battery.
Blank Display	1. The Braun ThermoScan has switched itself off automatically. 2. The battery is dead, improperly connected, or missing	Depress on-button  . Remove and reinstall battery. If the LCD-display remains blank, replace it with a fresh battery. If display is still blank, contact Braun.

- **If temperatures appear to be reading low**, ensure proper technique is being used (see page 11 to 12). Make sure the lens is clean and a new lens filter is attached.
- **If temperatures appear to be reading high**, be sure a new lens filter is attached. Inspect the lens; if it is damaged, the thermometer must be serviced.
- **To assure accuracy and sanitary practice**, Braun recommends replacing the lens filter after each use. Should you run out of lens filters and need to take a temperature, you may use the following lens filter cleaning procedure: Clean the lens filter without removing it from the thermometer with a soft cloth or cotton swab moistened with alcohol or mild soap and water. Do not use hot or boiling water. Dry completely with a soft cloth before reusing. Replace lens filter as soon as possible with a new one (LF 40).

Lens Tip

- The lens tip is the most delicate part of the thermometer. It is covered with a soft, thin membrane which forms a surface that is transparent to heat waves. To ensure accuracy, it is very important to keep the lens clean and intact, and to always keep a clean, new lens filter attached. Fingerprints, ear wax, dust and other soiling compounds reduce transparency of the lens, resulting in lower temperature readings. Remember: always store the thermometer in its cover when not in use.
- Inspect the lens whenever you replace a lens filter. To clean the lens, very gently wipe the surface with a cotton swab or soft cloth moistened with alcohol or mild soap and warm water (Figure 11). After cleaning, allow at least 45 minutes drying time before reattaching a lens filter and taking temperatures. If the lens is damaged, contact Braun.

Lens Filters

- Replace lens filter after each use. Make sure that the new lens filter is not damaged.
- Keep lens filters out of direct sunlight and ultraviolet light for extended periods of time. Store lens filters away from dust and contamination.

Thermometer

- Use a soft, dry, clean cloth to clean the instrument display and exterior. Do not use abrasive cleaners or submerge in water or other liquids.
- This instrument contains precision components and should not be subjected to extremes in temperature, humidity, direct sunlight, shock or dust.
- Store unit in a location where the temperature remains fairly constant and within the range of 16°C to 40°C (61°F to 104°F). To ensure that the Braun ThermoScan Thermometer is always ready to take a temperature (and avoid Err 4), store it in the room where it is most frequently used.

Care and cleaning

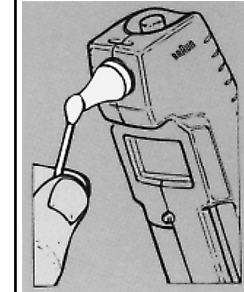

Figure 11

Calibration

The thermometer is initially calibrated at the time of manufacture. If this thermometer is used in accordance with the Use Instructions, periodic recalibration is not required. If at any time you question the accuracy of measurement, please contact Braun.

Lot number identification

The date of manufacture can be determined by referring to the instrument LOT number. This number can be found by opening the battery compartment and removing the battery. The number is preceded by the word "LOT" and is in the following format: XXOOOXX or XOOOXXX, where X designates alpha characters and O designates numbers. The first of the three numbers is the last digit of the year of manufacture. The next two numbers designate the week of the calendar year that it was manufactured.

For example: LOT X542XXX. this thermometer was manufactured during the 42nd week of 1995.

This product is guaranteed for 1 year from date of purchase against material and/or workmanship defects. These will be eliminated either by repairing or exchanging the appliance as we may choose. All other claims, including for damages, are excluded. Service under the guarantee does not affect its expiry date.

Claims only valid in countries where product is officially sold and if accompanied by a stamped and dated guarantee card. Claims arising out of the sales contract with the vendor are not affected by this guarantee.

For UK only:

This guarantee in no way affects your rights under statutory law.

Guarantee